

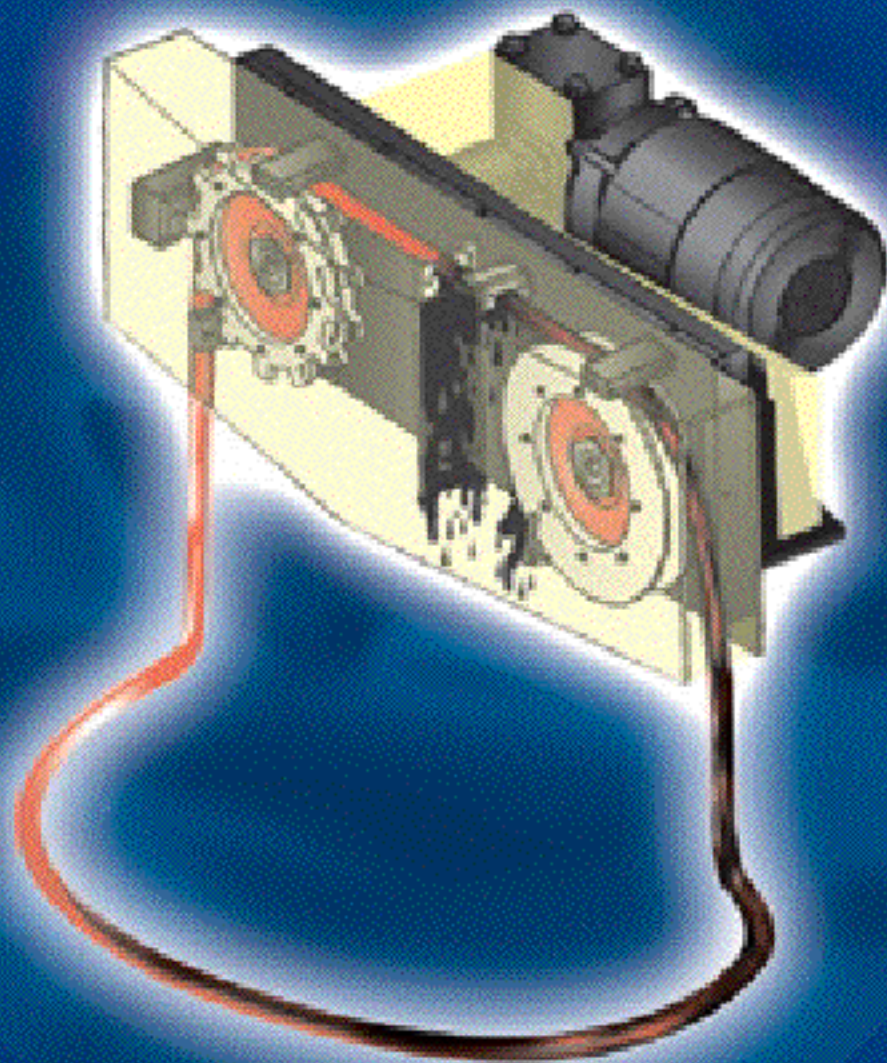

SKIMTECH™, Inc.

PROVIDING SKIMMING SOLUTIONS FOR INDUSTRIES WORLDWIDE



WWW.SKIMTECH.COM



SkimTech, Inc. has modernized the design of the *Tube or Rope Type* skimmer to bring it into the 21st Century and meet the needs of today's manufacturing and commercial environmental concerns. SkimTech manufactures the **Skimall**® family of *Tube Type* skimming systems, **TigerTube**™ collector tubes and tough **Dureon**™ wear parts. We also manufacture *upgrade kits* to improve the performance of your existing *Tube Type* skimming system. All our products can be ordered online.

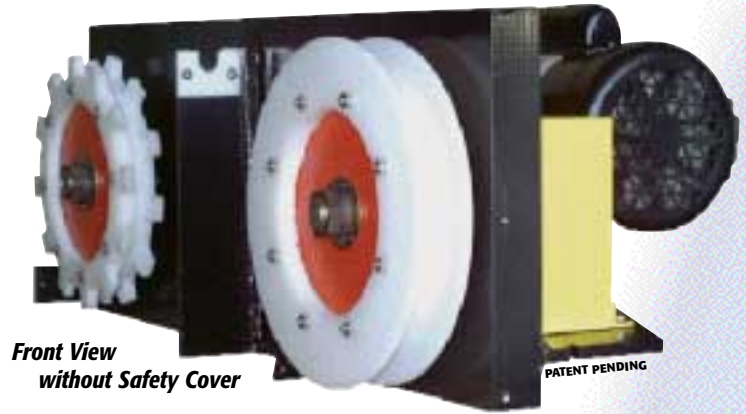

 **THREE MODELS AVAILABLE**

 **UNIQUE SAFETY FEATURES**

 **TRADITIONAL PROVEN PROCESS**

 **FITS EXISTING SKIMMER MOUNTS**

 **HIGH REMOVAL RATE CAPACITY**

 **PRE-ENGINEERED MOUNTS AVAILABLE**

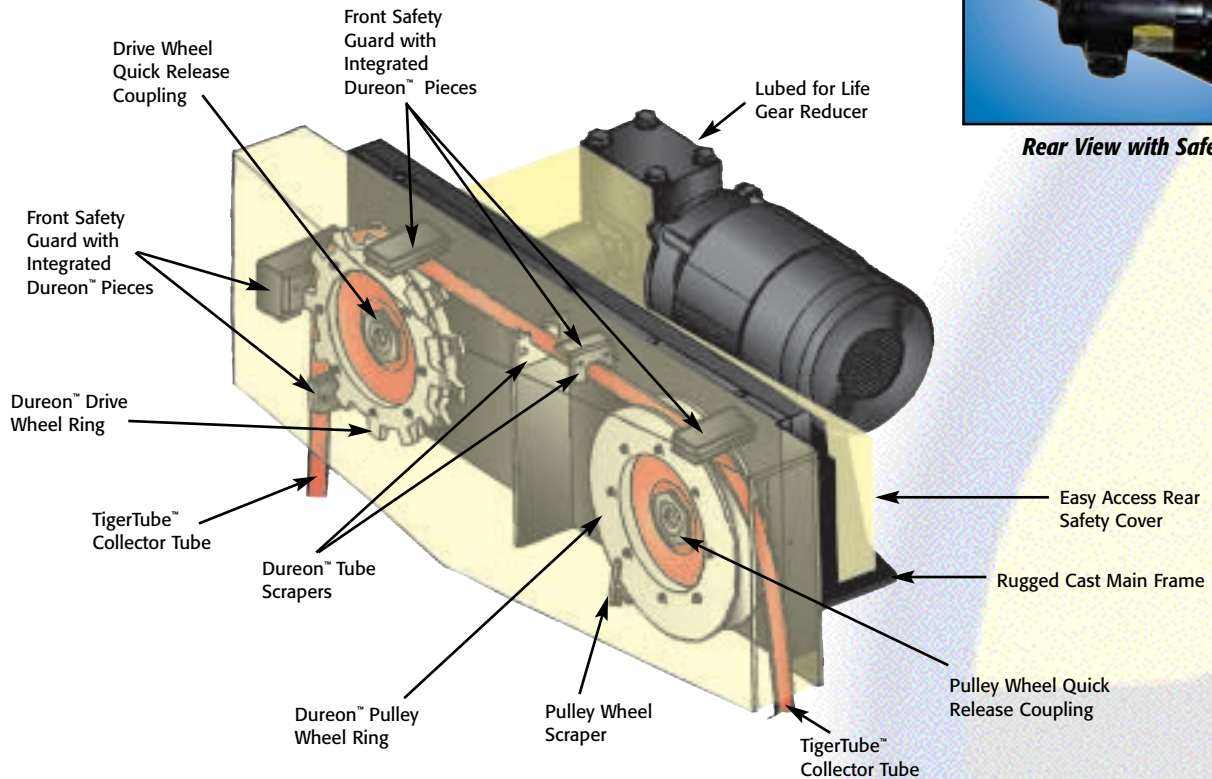

SKIMMER BASICS

Tube Type oil skimmers have been used in industrial applications for over 40 years. They are a proven method for removing free-floating contaminants from sumps, pits, ponds and hundreds of other applications. SkimTech's **Skimall**® skimmers can help improve the quality of process and discharge water for reuse or treatment. In many instances, the material removed can be reused or recycled which can save you costs.



No matter what your industry, SkimTech can help you solve your free-floating material removal problem. We are dedicated to applying the right skimming system for your application to save you time and money. Our skimmers are built to deliver years of performance in tough industrial applications.

Order Online: WWW.SKIMTECH.COM

SKIMALL® SKIMMERS

SkimTech's **Skimall**® skimmers are designed for high efficiency skimming. The low percentage of water removed helps you minimize costs. SkimTech's **Skimall**® skimmers are designed for **low maintenance** and **24/7** operation. Your investment in a skimming system is important; make sure it is the best skimmer for your application.

FEATURES INCLUDE:

- ▶ **Rugged** main frame available in coated cast aluminum (standard) or stainless steel (special order).
- ▶ **Lubed for life** bearings, sprockets and gear reducing components. No oil reservoir to fill and no seals that leak.
- ▶ Long-life **abrasive resistant Dureon™** tube scrapers and pressure blocks that are specially designed for tough industrial applications.
- ▶ Quick connect and release Drive and Pulley Wheels for ease of maintenance. Drive and Pulley Wheels have our unique universal **Dureon™** replacement rings...you may **never have to replace the entire wheel!**
- ▶ **Safety guards** designed with today's safety concerns in mind. If your existing skimming system functions properly without the safety guards in place, **you are vulnerable to potentially costly worker injury claims.** Safety is an important factor when evaluating which skimming system to buy!
- ▶ Front safety guard with integral **Dureon™** tube scrapers and pressure blocks. The guard prevents worker injuries, secures the **Dureon™** pieces in place and allows for easy access to the integral **Dureon™** pieces **without removing the skimmer from its mount!**
- ▶ Rear safety guard allows for easy access to the modern Drive and Pulley Wheel belt drive system.
No major disassembly required!
- ▶ Our **Dureon™** tube scrapers and pressure blocks pieces are designed to fit most *Tube Type* skimmers. See our **Upgrade Kits** to improve the performance of your existing *Tube Type* skimmer.

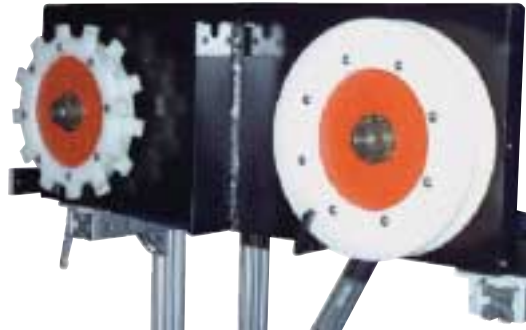

THREE MODELS AVAILABLE:

Skimall® Model BG01 "Mighty Mack" - The largest *Tube Type* skimmer available! Designed for large indoor and outdoor applications where high oil removal rates are essential - large settling basins, scale pits, cooling ponds and pre-filtration waste water treatment settling tanks. Uses **1" TigerTube™** for maximum oils, fats, and grease removal.

Skimall® Model BG34 "Lucy" - Also designed for indoor and outdoor applications where standard removal rates are sufficient - oil and grease settling basins, cooling water and settling ponds, and large multiple machine central coolant systems. Uses **3/4" TigerTube™** for standard oils, fats and grease removal rates and efficiency.

Skimall® Model AG25 "Mini David" - Designed for applications where space is limited - parts washers, small oil/water pre-filtration equalization tanks and central coolant systems. Uses standard **1/4" TigerTube™**. Fast and easy "Tramp Oil" removal.

PERFORMANCE • RELIABILITY • SAFETY

SKIMTECH

TIGERTUBE™



SkimTech's **TigerTube™** is specially formulated to maximize oil, fat and grease removal. It snakes around debris and is impervious to hot or cold applications. The tube is sized in length for the application and driven in a continuous floating loop by the skimmer. The **orange color** is the universal color for a moving part - another unique safety feature.

Animal fats, cooking oil, cutting oil, diesel fuel, fly ash, gasoline, grease, hydraulic oil, jet-a fuel, kerosene, lubricating oil, paint sludge, quench oil, RAD waste, silicone, solvents, sludge, soybean oil, tramp oil, vegetable oil, waste oil – no problem for the TigerTube™.

If you have ever experienced the frustration of *frequently breaking collector tubes*, SkimTech's **TigerTube™** is the solution. Replace your existing skimmer collector tube with the **TigerTube™**.



TYPICAL REMOVAL RATES



SKIMALL® SKIMMER MOUNTING

SkimTech offers a complete line of pre-engineered mounting systems designed for your application. Every mounting system is supplied complete with all assembly hardware and designed with today's safety regulations in mind.

FRAME MOUNTS

Complete with Sludge Pan,
3" Drain Coupling and Heater

~
60" Tall Frame Mount

~
30" Tall Frame Mount

~
18" Tall Frame Mount

~
Guard Rail Mount

~
Hanging Mount

OPTIONAL ITEMS

- Mini Oil/Water Separator
- Standard Oil/Water Separator
- Combination Sludge Pan and Oil/Water Separator
- 115 or 220 Volt Combination Sludge Pan and Oil/Water Separator Heater
- Debris Screen
- Rain/Snow Cover
- Wind Shield
- Complete Winterization Packages

BOOM MOUNTS

6' - 16' Long Boom Mounts
available for ponds, settling
basins and other applications
where long reach is important

~
4' - 8' Tall
Boom Support Masts

CUSTOM DESIGNED MOUNTS

Skimtech will design and
customize a Mounting System
for your application. Contact us
with your unique needs and we
will design a solution.

UPGRADE KITS AVAILABLE

SkimTech offers *Three Upgrade Kits* to improve the performance of your existing *Tube Type* skimmer.

- 1" TigerTube™ Upgrade
- 3/4" TigerTube™ Upgrade
- Dureon™ Wearpiece Upgrade

The 1" TigerTube™ Upgrade will dramatically increase the removal rate of a 3/4" Tube Type Skimmer.

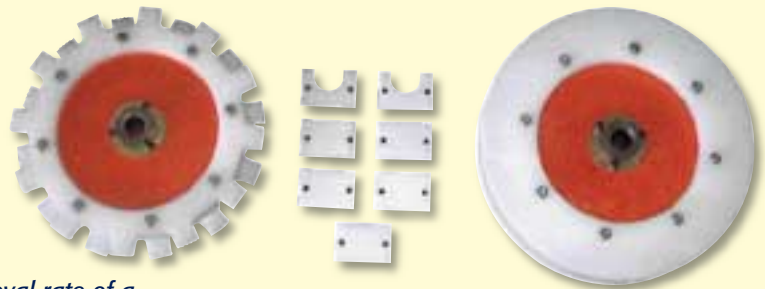

GUARANTEE

Your satisfaction is our primary concern...

SkimTech guarantees every **Skimall**® skimming system will operate to your satisfaction. Every **Skimall**® system is designed to deliver years of reliable service and manufactured to the highest quality standards.

See our website for complete details.

...We are here to be of service.



P.O. Box 5205 • Youngstown, OH 44514
Phone/Fax: 330-757-7606

WWW.SKIMTECH.COM